

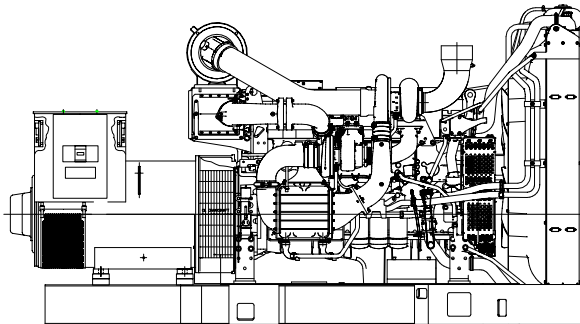

# MAQUINARIA IGSA POWER GENERATION SYSTEMS



**MODEL: GSVO20500S**  
**DIESEL ENGINE: VOLVO**  
**MODEL: TAD1641GE, TIER II**  
**CAPACITY: 500 KW 60 HZ,**

RATINGS RANGE	
<b>PRIME hp(KW)</b> 660 (485)	<b>STANDBY hp (KW)</b> 743 (546)

The Genset performance corresponds to ISO 3046, BS 5514 and DIN 6271.

## STANDARD FEATURES

Complete system designed and built at ISO9001 certified facility

- Factory tested to design specifications at full load conditions.
- Fully engineered with a range of options and accessories.

**1 IGSA** Genset's are composed of 6 cylinders in line and four strokes diesel engine for industrial stationary applications. Those equipments are fully factory tested using a resistive load. (1) Hour ramp 100% load test.

**2** The controls and accessories are selected to work together to achieve the maximum operational performance and security.

**3** Exhaust: stainless steel exhaust flex and ANSI outlet flange.

**4** Engine VOLVO, **TAD1641GE TIER II**

**5** Stamford Alternator

**6** Control MEC310 (USC300).

**7** Base of structural steel.

**8** Standard and optional equipment may vary for UL 2200 listed packages. UL 2200 listed packages may have oversized generators with a different temperature rise and motor starting characteristics.

## GENERAL FEATURES

- IGSA GENSET of **500 kW to 480V, 440V, 380V, 208VAC**. 3 Phase, 4 Wire, 60 Hertz, is composed by an internal engine four strokes coupling with the alternator, controls and accessories totally assembled and tested in factory.
- The controls and accessories of the Genset are selected to provide the maximum in efficiency and Security
- The generator set its components are tested factory-built, and production-tested.
- The genset engine is certified by the Environmental Protection Agency (EPA) to conform to Tier 2 nonroad emissions regulations.
- Electronic engine controls manage the engine (isochronous)
- Integrated complete system control and monitoring (EMS 2)



WE ARE THE BEST IN MANUFACTURING THE POWER GENERATION SYSTEMS AND ADDITION CONSTANTLY INNOVATION.

[www.igsa.com.mx](http://www.igsa.com.mx)  
 All rights reserved.  
 Printed in MEXICO

# ENGINE SPECIFICATION DATA MODEL TAD 1641GE

## Weight 1910 Kg (4211 Lb) With Gen Pac

General Data		
Model	TAD 1641GE	
Number of Cylinders	In line 6	
Method of operation	4 stroke	
Bore and Stroke--mm (in)	144x165 (5.67x6.50)	
Displacement--l (in.3)	16.12 (983.7)	
Compression Ratio	16.5:1	
Physical Data		
Length-- mm(in)	--	
Width--mm(in)	1120 (44.1)	
Height-- mm(in)	1587 (62.5)	
Weight with gen pac, <dry--kg (lb)	1910 (4211)	
Performance Data		
With fan, kW (hp) at:	1800 rpm	
Prime Power	485 (660)	
Max Standby Power	546 (743)	
Lubrication System		
Oil consumption, liter/h (US gal/h) at:	1800 rpm	
Prime Power	0.11 (0.029)	
Max Standby Power	0.12 (0.032)	
Oil System Capacity incl filters, liter	42	
Fuel Consumption -- kg/hr (lb/hr)		
	Prime	Sandby
25 % Power	232 (0.376)	228 (0.370)
50 % Power	202 (0.327)	201 (0.326)
75 % Power	197 (0.319)	197 (0.319)
100 % Power	200(0.324)	205 (0.332)
Intake and exhaust system		
Air consumption, m <sup>3</sup> /min (cfm) at:	1800 rpm	
Prime Power	42 (1483)	
Max Standby Power	45 (1589)	
Max Allowable air intake restriction, kPa (In wc)	5 (20.1)	
Heat rejection to eshaust, kW (BTU/min) at:	--	
Prime Power	373 (21212)	
Max Standby Power	442 (25136)	
Exhaust gas temperature after turbine °C (°F) at:		
Prime Power	435 (815)	
Max Standby Power	470 (878)	
Max Allowable back-pressure in exhaust line, kPa (In wc)	10 (40.2)	
Exhaust gas flow, m <sup>3</sup> /min (cfm) at:	--	
Prime Power	97.0 (3426)	
Max Standby Power	106.6 (37.65)	
Cooling System		
Heat rejection radiation from engine, kW (BTU/min) at:	1800 rpm	
Prime Power	32 (1820)	
Max Standby Power	33 (1877)	
Heat rejection to coolant, kW (BTU/min) at:	1800 rpm	
Prime Power	185 (10521)	
Max Standby Power	199(11317)	
Fan Power consumption, kW (hp)	19 (26)	



**WE ARE THE BEST IN MANUFACTURING THE POWER GENERATION SYSTEMS AND ADDITION CONSTANTLY INNOVATION.**

[www.igsa.com.mx](http://www.igsa.com.mx)  
All rights reserved.  
Printed in MEXICO

# STAMFORD ELECTRIC ALTERNATOR MODEL HCI534D/544D

## weight 1393 kg (3071 lb)

<b>CONTROL SYSTEM</b>	<b>SEPARATELY EXCITED BY P.M.G.</b>		
<b>A.V.R.</b>	<b>MX321</b>	<b>MX341</b>	
<b>VOLTAGE REGULATION</b>	<b>(+/- 0.5%)</b>	<b>(+/- 1.0%)</b>	<b>WITH 4% ENGINE GOVERNING</b>
<b>SUSTAINED SHORT CIRCUIT</b>	<b>REFERENT TO SHOT CIRCUIT DECREMENT CURRENT</b>		

INSULATION SYSTEM	CLASS H							
PROTECTION	IP23							
RATED POWER FACTOR	0.8							
STATOR WINDING	DOUBLE LAYER CONCENTRIC							
WINDING PITCH	TWO THIRDS							
WINDING LEADS	12							
STATOR WDG. RESISTANCE	0.005 Ohms PER PHASE AT 22°C SERIES STAR CONNECTED							
ROTOR WDG. RESISTANCE	1.77 Ohms at 22°C / 72 °F							
R.F.I. SUPPRESSION	BS EN 61000-6-2 & BS EN 61000-6-4,VDE 0875G, VDE 0875N. refer to factory for others							
WAVEFORM DISTORTION	NO LOAD < 1.5% NON-DISTORTING BALANCED LINEAR LOAD < 5.0%							
MAXIMUM OVERSPEED	2250 Rev/Min							
BEARING DRIVE END	BALL. 6220 (ISO)							
BEARING NON-DRIVE END	BALL. 6314 (ISO)							
WEIGHT COMP. GENERATOR	1 BEARING				2 BEARING			
WEIGHT WOUND STATOR	1393 kg / 3071lb				1395 kg / 3075.4lb			
WEIGHT WOUND ROTOR	657 kg / 1448.4 lb				657 kg / 1448.4 lb			
WR <sup>2</sup> INERTIA	563 kg / 1241.2 lb				535 kg / 1179.5 lb			
SHIPPING WEIGHTS in a crate	8.0068 kg/m <sup>2</sup> / 1.64 Lb/ft <sup>2</sup>				7.7289 kgm <sup>2</sup> / 1.58Lb/ft <sup>2</sup>			
PACKING CRATE SIZE	1485 kg / 3273.9 lb				1485 kg / 3273.9 lb			
	166 x 87 x 124 (cm) / 65.35x34.25x48.81 (inch)				166 x 87 x 124 (cm) / 65.35x34.25x48.81 (inch)			
TELEPHONE INTERFERENCE	50 Hz				60 Hz			
COOLING AIR	THF<2%				TIF<50			
	1.035 m <sup>3</sup> /sec 2202 cfm				1.312 m <sup>3</sup> /sec 2780 cfm			
VOLTAGE SERIES STAR	380/220	400/231	415/240	440/254	416/240	440/254	460/266	480/277
VOLTAGE PARALLEL STAR	190/110	200/115	208/120	220/127	208/120	220/127	230/133	240/138
VOLTAGE SERIES DELTA	220/110	230/115	240/120	254/127	240/120	254/127	266/133	277/138
KVA BASE RATING FOR REACTANCE VALUES	500	500	500	500	575	594	625	644
Xd DIR. AXIS SYNCHRONOUS	3.02	2.72	2.53	2.25	3.52	3.25	3.13	2.96
X'd DIR. AXIS TRANSIENT	0.16	0.14	0.13	0.12	0.17	0.16	0.15	0.14
X''d DIR. AXIS SUBTRANSIENT	0.11	0.10	0.09	0.08	0.12	0.11	0.11	0.10
Xq QUAD. AXIS REACTANCE	2.48	2.24	2.08	1.85	2.87	2.65	2.55	2.41
X''q QUAD. AXIS SUBTRANSIENT	0.27	0.25	0.23	0.20	0.31	0.29	0.28	0.26
XL LEAKAGE REACTANCE	0.05	0.04	0.04	0.04	0.06	0.08	0.05	0.05
X2 NEGATIVE SEQUENCE	0.19	0.17	0.16	0.14	0.22	0.20	0.20	0.19
X0 ZERO SEQUENCE	0.10	0.09	0.08	0.07	0.10	0.09	0.09	0.08
REACTANCES ARE SATURATED				VALUES ARE PER UNIT AT RATING AND VOLTAGE INDICATED				
T'd TRANSIENT TIME CONST.	0.08 s							
T''d SUB-TRANSTIME CONST.	0.012 s							
T'do O.C. FIELD TIME CONST.	2.2 s							
Ta ARMATURE TIME CONST.	0.018 s							
SHORT CIRCUIT RATIO	1/Xd							

RATINGS: All three-phase units are rated at 0.8 power factor. All single-phase units are rated at 1.0 power factor. Standby Ratings: Standby ratings apply to installations served by a reliable utility source. The standby rating is applicable to varying loads for the duration of a power outage. There is no overload capability for this rating. Ratings are in accordance with ISO-3046/1, BS5514, AS2789, and DIN 6271. Prime Power Ratings: Prime power ratings apply to installations where utility power is unavailable or unreliable. At varying load, the number of generator set operating hours is unlimited. A 10% overload capacity is available for a 12 hours period. Ratings are in accordance with ISO-8528/1, overload power in accordance with ISO-3046/1, BS 5514, AS 2789, and DIN 6271. For limited running time and base load ratings, consult the factory. The generator set manufacturer reserves the right to change the design or specifications without notice and without any obligation or liability whatsoever. GENERAL GUIDELINES FOR DERATION: Altitude: Derate 0.4% per 100 m (328 ft.) elevation above 1400m (4593 ft.). Temperature: Derate 5.0% per 10°C (18°F) temperature above 40°C (104°F).



**WE ARE THE BEST IN MANUFACTURING THE POWER GENERATION SYSTEMS AND ADDITION CONSTANTLY INNOVATION.**

[www.igsacom.mx](http://www.igsacom.mx)  
All rights reserved.  
Printed in MEXICO

## CONTROLLER FOR GENSET: MEC 20 UL

The Generator Controller MEC 310 is a microprocessor-based control unit containing all necessary functions for protection and control of a power generator. Besides the control and protection of the diesel engine it contains a full 3-phase AC voltage and current measuring circuit. The unit is equipped with an LCD display presenting all values and alarms.



- USC 300C Unit Mount Control Panel, Black Nema 1 enclosure c/w rubber mounts
- MEC 310 Microprocessor Based Engine Generator Controller
- Graphic Display 128 X 64 pixels (STN) Super Twisted Nematic
- Digital AC Metering:
  - 3-Phase Volts (Phase to Phase and Phase to Neutral),
  - 3-Phase Amps
  - Frequency
  - kW, kVAR, KVA, pF, kWhr
- AC Protective Relaying:
  - 27/59 Under/Over Voltage
  - 32 Reverse Power
  - 51 Time Overcurrent
  - 81 O/U Under/Over Frequency
- Digital gauge display:
  - Oil Pressure (sender required by others)
  - Coolant Temperature (sender required by others)
  - Fuel Level (sender required by others)
  - Hourmeter
  - Tachometer
- 5 digital inputs for alarms / shutdowns
- Dedicated Output Contacts - Engine Crank; Run (30 VDC / 6 Amps)
- Three Programmable Output Contacts (30 VDC / 1 Amps)
- Event Logging (30 events)
- Pushbuttons:
  - Emergency Stop
  - Manual Start and Stop
  - Manual/Auto/Test
  - Lamp Test
  - Horn Silence
- Indicating Lights:
  - Common Alarm
  - Generator Ready (Voltage and Frequency Normal)

## FEATURES

- Electrical Rating:** - Single or three phase, 600VAC maximum, 50/60HZ, 4 wire  
- 12 or 24Vdc (nominal) supply, negative ground.
- Enclosure:** - Black NEMA/EEMAC; vibration isolated.
- Engine Senders:** - Oil pressure (1/8" NPT), Temperature (1/4"NPT) (Supplied loose for engine mounting).
- Miscellaneous:** -AC & DC fuses, vibration isolators, terminal blocks.

## OPTIONAL SILENCER ACCORDING TO THE APPLICATION

Silencer with different levels from attenuation

- Critical Grade
- Super Critical Grade
- Hospital Grade

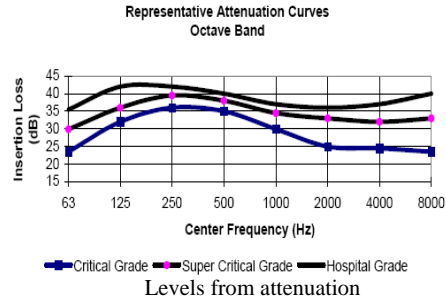

## DOCUMENTATION AND OTHERS

- Manual of operation and maintenance
- Spare parts
- Maintenance
- Consulting

## MISCELLANEOUS EQUIPMENT

- Batteries of 12 VDC with cables for battery connection with the engine.

### GENSET OPTIONS

#### Control Panel

USC 300C Control Panel is standard on all units see page 4 of spec sheet for standard features.

Another Type \_\_\_\_\_

#### Fuel system

- Fuel Water Separator
- Day tank
- Auxiliary fuel pump
- Sub Base mounted Fuel Tank
  - Single Wall
  - Double Wall
  - UL listed

#### Diesel Fuel Tank

- 1000 L (264.1 gal)
- 5000 L (1320.8 gal)
- 15000 L (3962.5 gal)

#### Exhaust System

- Critical Grade
- Super Critical Grade
- Hospital Grade

#### Engine Electrical system

- Battery
  - Lead-Acid
  - NiCad
- Battery Rack
- Battery Charger Automatic

#### Generator

- Breaker in the alternator
- PMG excitation & DVR 2000E Regulator
- A.V.R (MX321)
- A.V.R (MX341)

### OPTIONAL ACCESSORIES AVAILABLE FOR THE EQUIPMENT

#### Vibration isolation

- Rigid Spring Mounting
- Resilient Mounting

#### Filters

- Air Filter for Medium Dust Environments
- Air Filter of Heavy Dust Environments

#### Drain

- Oil drain Extension

#### Enclosures

- Sound Attenuated
- Weather Proof
- Stainless steel cover
- Trailer Mounting
- Interior lights Ac or DC

#### Heaters

- Jacket Water Heater
- Crankcase Oil Heater

#### Insulation Blankets

- Features:
  - ( Temperature to 1260°C (2300°F), Non-Combustible, Highly Resistant to Vibration, Oil, Fuel, Grease, and Moisture Resistant Exterior, Personal Protection

#### Notes

---



---



---



---

## DIMENSIONS

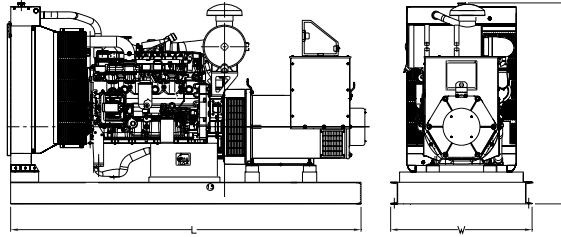

LENGTH	WIDTH	HEIGHT
mm (in)	mm (in)	mm (in)
3310 (130.3)	1120 (44.1)	1590 (63)

NOTE: General configuration not to be used for installation. See general dimension drawing for detail.

## SERVICES

- Development of the project.
- Development of engineering.
- Development of project Turn Key.
- Equipment's Installation
- Engineering for special applications.
- Synchronies with utility network or more Gensets.

## INSTALLATION OPTIONS OF THE GENSET

- On-Site
- Acoustic Enclosure
- ISO Container
- Trailer

