

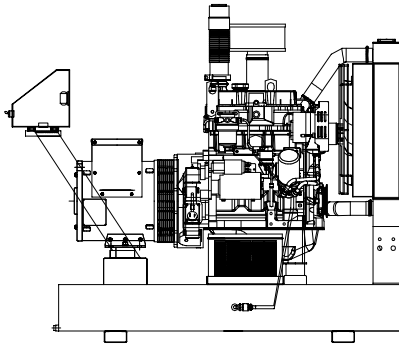

MAQUINARIA IGSA POWER GENERATION SYSTEMS



MODEL: GSJD00030M
DIESEL ENGINE: JOHN DEERE
MODEL: 3029DF120
NON CERTIFICATE
CAPACITY: 30kW; 1800 RPM

RATINGS RANGE	
PRIME hp (kW)	STANDBY hp (kW)
33.5 - 34.8 (25-26)	37.5 - 40.2 (28-30)

Note: Gross power guaranteed within + or - 5%
ISO 3046 conditions:
77°F (25°C) Air inlet temperature
29.31 in.Hg(99KPa) Barometer
104 °F (40°C) fuel inlet temperature
0.853 fuel specific gravity @ 60°F (15.5 °C)

STANDARD FEATURES

Complete system designed and built at ISO9001 certified facility

- Factory tested to design specifications at full load conditions.
- Fully engineered with a range of options and accessories.

1 IGSA Genset's are composed of 3 cylinders in line and four strokes diesel engine for industrial stationary applications. Those equipments are fully factory tested using a resistive load. (1) Hour ramp 100% load test.

2 The controls and accessories are selected to work together to achieve

the maximum operational performance and security.

3 Exhaust gases silencer, and a section of flexible tube for connection purposes.

4 Engine **JOHN DEERE, 3029DF120 NON CERTIFICATE**

5 Marathon Alternator

6 Radiator

7 Control MEC 310 (panel USC300)

8 Base of structural steel

GENERAL FEATURES

- IGSA GENSET of, **30Kw to 480V, 440V, 380V, 220V, 208V, 190VAC**, 3 Phase, 4 Wire, 60 Hertz, is composed by an internal engine four strokes coupling with the alternator, controls and accessories totally assembled and tested in factory.
- The controls and accessories of the Genset are selected to provide the maximum in efficiency and Security
- The generator set its components are tested factory-built, and production-tested.



WE ARE THE BEST IN MANUFACTURING THE POWER GENERATION SYSTEMS AND ADDITION CONSTANTLY INNOVATION.

www.igsa.com.mx
All rights reserved.
Printed in MEXICO

ENGINE SPECIFICATION DATA MODEL 3029DF120

Weight 316 Kg (696 Lb)

General Data		
Model	3029DF120	
Number of Cylinders	3	
Bore and Stroke--in.(mm)	4.20 x 4.33 (106 x 110)	
Displacement--in.3 (L)	179 (2.9)	
Compression Ratio	17.2 : 1	
Valves per Cylinder--Intake/Exhaust	1 / 1	
Firing Order	1 - 2 - 3	
Combustion System	Direct Injection	
Engine Type	In-line, 4-Cycle	
Aspiration	Natural	
Engine Crankcase Vent System	Open	
Maximum Crankcase Pressure--in.H2O (kPa)	2 (0.5)	
Physical Data		
Length--in.(mm)	28.2 (716)	
Width--in.(mm)	20.4 (519)	
Height--in.(mm)	32.2 (819)	
Weight, dry--lb (kg) (Includes SAE 4 flywheel housing, RE28119 flywheel, starter and electrics.)	696 (316)	
Center of Gravity Location		
From Rear Face of Block (X-axis)--in.(mm)	7.8 (198)	
Right of Crankshaft (Y-axis)--in.(mm)	0.3 (10)	
Above Crankshaft (Z-axis)--in.(mm)	4.9 (124)	
Max. Allow. Static Bending Moment at Rear Face of Flywhl Hsg w/ 5-G Load--lb-ft (N*m)	600 (814)	
Thrust Bearing Load Limit (Forward)		
Continuous--lb (N)	500 (2224)	
Intermittent--lb (N)	900 (4003)	
Performance Data	Prime	Sandby
Rated Power--hp (kW)	33.5 -34.8 (25-26)	37.5 -40.2 (28-30)
Rated Speed--rpm	1800	1800
Low Idle Speed--rpm	1400	1400
BMEP--psi (kPa)	130(710)	116 799)
Friction Power		
Rated Speed--hp (kW)	21 (16)	21 (16)
Altitude Capability--ft (m)	1000(300)	1000(300)
Ratio--Air : Fuel.	23.7:1	21.7:1
Noise--dB(A) @ 1 m	92.4	92.7
Air System	Prime	Sandby
Maximum Allowable Temp Rise--Ambient Air to Engine Inlet--°F (°C)	15 (8)	15 (8)
Maximum Air Intake Restriction		
Dirty Air Cleaner--in.H2O (kPa)	25 (6.25)	25 (6.25)
Clean Air Cleaner--in.H2O (kPa)	12 (3)	12 (3)
Engine Air Flow--ft3/min (m3/min)	78 (2.2)	80 (2.3)
Intake Manifold Pressure--psi (kPa)	Ambient	Ambient
Rec'd. Intake Pipe Dia--in.(mm)	2.5 (63.5)	2.5 (63.5)

Electrical System		
Recommended Battery Capacity (CCA)		
12 Volt System--amp		640
24 Volt System--amp		570
Maximum Allowable Starting Circuit Resistane		
12 Volt System--Ohm		0.0012
24 Volt System--Ohm		0.002
Starter Rolling Current -- 12 Volt System		
At 32 F (0 C) -- amp		780
At -22 F (-30 C) -- amp		1000
Starter Rolling Current -- 12 Volt System		
At 32 F (0 C) -- amp		600
At -22 F (-30 C) -- amp		700
Lubrication System	Prime	Sandby
Oil Pressure at Rated Speed--psi (kPa)	50 (345)	50 (345)
Oil Pressure at Low Idle--psi (kPa)	15 (105)	15 (105)
In Pan Oil Temperature--°F (°C)	240 (115)	240 (115)
Oil Pan Capacity, High--qt (L)	5.3 (5)	5.3 (5)
Oil Pan Capacity, Low--qt (L)	4.3 (4.1)	4.3 (4.1)
Total Engine Oil Capacity		
With Filters--qt (L)	6.3 (6)	6.3 (6)
Engie Angularity Limits		
(Continuous) Any Direction--degrees	20	20
Exhaust System	Prime	Sandby
Exhaust Flow--ft3/min (m3/min)	218 (6.1)	225 (6.4)
Exhaust Temperature--°F (°C)	1060(570)	1066(630)
Max. Allow. Back Press.--in.H2O (kPa)	30 (7.5)	30 (7.5)
Recm'd Exhaust Pipe Dia--in.(mm)	2.5 (63.5)	2.5 (63.5)
Cooling System	Prime	Sandby
Engine Heat Reject--BTU/min (kW)	1008 (18)	1120 (20)
Coolant Flow--gal/min (L/min)	29 (110)	29 (110)
Thermostat Start to Open--°F (°C)	180 (82)	180 (82)
Thermostat Fully Open--°F (°C)	202 (94)	202 (94)
Maximum Water Pump		
Inlet Restriction--in.H2O (kPa)	27 (7)	27 (7)
Engine Coolant Capacity--qt (L)	6 (5.7)	6 (5.7)
Recm'd Pressure Cap--psi (kPa)	10 (69)	10 (69)
Maximum Top Tank Temp--°F (°C)	221 (105)	221 (105)
Min. Coolant Fill Rate--gal/min (L/min)	3 (11)	3 (11)
Min. Air-to-Boil Temperature--°F (°C)	117 (47)	117 (47)
Fuel System	Prime	Sandby
Fuel Injection Pump	Stanadyne	Stanadyne
Governor Regulation	5%	5%
Governor Type	Mechanical	Mechanical
Total Fuel Flow--lb/hr (kg/hr)	210 (95)	210 (95)
Fuel Consumption--lb/hr (kg/hr)	14.8 (6.7)	16.9 (7.7)
Maximum Fuel Transfer Pump Suction ft (m) fuel	3 (0.9)	3 (0.9)
Fuel Filter Micron Size @ 98 % Efficiency	8	8
Fuel Consumption -- lb/hr (kg/hr)	Prime	Sandby
25 % Power	5.0 (2.0)	5.3 (2.4)
50 % Power	8.4 (3.8)	9.5 (4.3)
75 % Power	11.9 (5.4)	13.3 (6.0)
100 % Power	14.8 (6.7)	16.9 (7.7)



WE ARE THE BEST IN MANUFACTURING THE POWER GENERATION SYSTEMS AND ADDITION CONSTANTLY INNOVATION.

www.iqsa.com.mx
All rights reserved.
Printed in MEXICO

MARATHON ELECTRIC ALTERNATOR MODEL 283CSL1507

Weight 158.7 Kg (350 Lb)

Kilowatt ratings		1800 RPM			60 Hertz		12 Leads		
kW (kVA)		3 Phase			0.8 Power Factor		Dripproof or Open Enclosure		
Voltage	Class B	Class F					Class H		
	80° C (1), 176°F	90° C (1), 194°F	95° C (1), 203°F	105° C † 221°F	105° C (1), 221°F	130° C (1), 266°F	125° C † 257°F	125° C (1), 257°F	150° C (1), 302°F
	Continuous	Lloyds	ABS	British Standard	Continuous	Standby	British Standard	Continuous	Standby
240/480	27.0 (33.8)	28.0 (35.0)	28.0 (35.0)	31.0 (38.8)	31.0 (38.8)	33.0 (41.3)	33.0 (41.3)	33.0 (41.3)	35.0 (43.8)
230/460	26.0 (32.5)	27.0 (33.8)	27.0 (33.8)	30.0 (37.5)	30.0 (37.5)	32.0 (40.0)	32.0 (40.0)	32.0 (40.0)	34.0 (42.5)
220/440	25.0 (31.3)	26.0 (32.5)	26.0 (32.5)	28.0 (35.0)	28.0 (35.0)	31.0 (38.8)	31.0 (38.8)	31.0 (38.8)	33.0 (41.3)
208/416	24.0 (30.0)	25.0 (31.2)	25.0 (31.2)	27.0 (33.8)	27.0 (33.8)	30.0 (37.5)	30.0 (37.5)	30.0 (37.5)	32.0 (40.0)
190/380	22.0 (27.5)	23.0 (28.8)	23.0 (28.8)	25.0 (31.3)	25.0 (31.3)	27.0 (33.8)	27.0 (33.8)	27.0 (33.8)	29.0 (36.3)

(1) Rise by resistance method, Mil-Std-705, Method 680.1b.

† Rating per BS 5000.

Submittal Data: 480 Volts, 25.0 kVA, 1800 RPM, 60 Hz, 3 Phase					
Mil-Std-705C			430.1a	T'do Transient Open Circuit Time Constant	0.8 sec.
Method	Description	Value	432.1a	Ta Short Circuit Time Constant of Armature Winding	0.0167 sec.
301.1b	Insulation Resistance	> 1.5 Meg	Mil-Std-705C		
302.1a	High Potential Test		Method	Description	Value
	Main Stator	2000 Volts	505.3b	Overspeed	2250 RPM
	Main Rotor	1500 Volts	507.1c	Phase Sequence CCW-ODE	ABC
	Exciter Stator	1500 Volts	601.4a	L-L Harmonic Maximum - Total (Distortion Factor)	3.0%
	Exciter Rotor	1500 Volts	601.4a	L-L Harmonic Maximum - Single	2.5%
401.1a	Stator Resistance, Line to Line		601.1c	Deviation Factor	6.0%
	High Wye Connection	0.438 Ohms	--	TIF (1960 Weightings)	<50
	Rotor Resistance	1.183 Ohms	Additional Prototype Mil-Std Methods are Available on Request.		
	Exciter Stator	18.83 Ohms	--	Generator Frame	280
	Exciter Rotor	0.127 Ohms	--	Type	Ext. Voltage Regulated, Brushless
410.1a	No Load Exciter Field Amps at 480 Volts Line to Line	0.49 A DC	--	Insulation	Class H
420.1a	Short Circuit Ratio	0.78	--	Coupling - Single Bearing	Flexible
421.1a	Xd Synchronous Reactance	1.91 pu	--	Amortisseur Windings	Full
422.1a	X2 Negative Sequence Reactance	0.215 pu	--	Cooling Air Volume	250 CFM
423.1a	X0 Zero Sequence Reactance	0.04 pu	--	Exciter	Rotating
425.1a	X'd Transient Reactance	0.0689 pu	--	Voltage Regulator	SE351
426.1a	X" d Subtransient Reactance	0.0645 pu	--	Voltage Regulation	1%
427.1a	T'd Transient Short Circuit Time Constant	0.025 sec.	--		
428.1a	T" d Subtransient Short Circuit Time Constant	0.008 sec.	--		

RATINGS: All three-phase units are rated at 0.8 power factor. All single-phase units are rated at 1.0 power factor. Standby Ratings: Standby ratings apply to installations served by a reliable utility source. The standby rating is applicable to varying loads for the duration of a power outage. There is no overload capability for this rating. Ratings are in accordance with ISO-3046/1, BS5514, AS2789, and DIN 6271. Prime Power Ratings: Prime power ratings apply to installations where utility power is unavailable or unreliable. At varying load, the number of generator set operating hours is unlimited. A 10% overload capacity is available for a 12 hour period. Ratings are in accordance with ISO-8528/1, overload power in accordance with ISO-3046/1, BS 5514, AS 2789, and DIN 6271. For limited running time and base load ratings, consult the factory. The generator set manufacturer reserves the right to change the design or specifications without notice and without any obligation or liability whatsoever. GENERAL GUIDELINES FOR DERATION: Altitude: Derate 1.3% per 100 m (328 ft.) elevation above 2000 m (6560 ft.). Temperature: Derate 1.0% per 10°C (18°F) temperature above 40°C (104°F).



WE ARE THE BEST IN MANUFACTURING THE POWER GENERATION SYSTEMS AND ADDITION CONSTANTLY INNOVATION.

www.igs.com.mx
All rights reserved.
Printed in MEXICO

CONTROLLER FOR GENSET: CONTROL MEC 310 PANEL USC300

The Generator Controller MEC 310 is a microprocessor-based control unit containing all necessary functions for protection and control of a power generator. Besides the control and protection of the diesel engine it contains a full 3-phase AC voltage and current measuring circuit. The unit is equipped with an LCD display presenting all values and alarms.



- USC 300C Unit Mount Control Panel, Black Nema 1 enclosure c/w rubber mounts
- MEC 310 Microprocessor Based Engine Generator Controller
- Graphic Display 128 X 64 pixels (STN) Super Twisted Nematic
- Digital AC Metering:
 - 3-Phase Volts (Phase to Phase and Phase to Neutral),
 - 3-Phase Amps
 - Frequency
 - kW, kVAR, KVA, pF, kWhr
- AC Protective Relaying:
 - 27/59 Under/Over Voltage
 - 32 Reverse Power
 - 51 Time Overcurrent
 - 81 O/U Under/Over Frequency
- Digital gauge display:
 - Oil Pressure (sender required by others)
 - Coolant Temperature (sender required by others)
 - Fuel Level (sender required by others)
 - Hourmeter
 - Tachometer
- 5 digital inputs for alarms / shutdowns
- Dedicated Output Contacts - Engine Crank; Run (30 VDC / 6 Amps)
- Three Programmable Output Contacts (30 VDC / 1 Amps)
- Event Logging (30 events)
- Pushbuttons:
 - Emergency Stop
 - Manual Start and Stop
 - Manual/Auto/Test
 - Lamp Test
 - Horn Silence
- Indicating Lights:
 - Common Alarm
 - Generator Ready (Voltage and Frequency Normal)

FEATURES

- Electrical Rating:**
- Single or three phase, 600VAC maximum, 50/60HZ, 4 wire
 - 12 or 24Vdc (nominal) supply, negative ground.
 - Dedicated Output Contacts - Engine Crank; Run (30 VDC / 6 Amps)
 - Three Programmable Output Contacts (30 VDC / 1 Amps)
- Enclosure:**
- Black Nema 1 enclosure c/w rubber mounts
- Engine Senders:**
- Oil pressure (1/8" NPT), Temperature (1/4"NPT) (Supplied loose for engine mounting).
- Requirements:**
- Exceeds requirements of CSA 282 and NFPA 110 Level

OPTIONAL SILENCER ACCORDING TO THE APPLICATION

Silencer with different levels from attenuation

- Critical Grade
- Super Critical Grade
- Hospital Grade

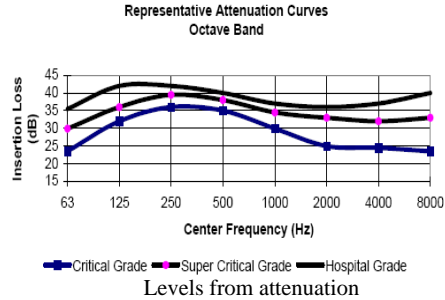

DOCUMENTATION AND OTHERS

- Manual of operation and maintenance
- Spare parts
- Maintenance
- Consulting

MISCELLANEOUS EQUIPMENT

- Batteries of 12 VCD with cables for battery connection with the Engine

GENSET OPTIONS

Control Panel

USC 300C Control Panel is standard on all units see page 4 of spec sheet for standard features.

Another Type _____

Fuel system

- Fuel Water Separator
- Day tank
- Auxiliary fuel pump
- Sub Base mounted Fuel Tank
 - Single Wall
 - Double Wall
 - UL listed
 - 150 L (39.6 gal)
 - 250 L (66 gal)

Diesel Fuel Tank

- 500 L (132 gal)
- 1000 L (264.1 gal)
- 5000 L (1320.8 gal)

Exhaust System

- Critical Grade
- Super Critical Grade
- Hospital Grade

Engine Electrical system

- Battery
 - Lead-Acid
 - NiCad
- Battery Rack
- Battery Charger Automatic

Generator

- Breaker in the alternator

OPTIONAL ACCESSORIES AVAILABLE FOR THE EQUIPMENT

Vibration isolation

- Rigid Spring Mounting
- Resilient Mounting

Filters

- Air Filter for Medium Dust Environments
- Air Filter of Heavy Dust Environments

Drain

- Oil drain Extension

Enclosures

- Sound Attenuated
- Weather Proof
- Stainless steel cover
- Trailer Mounting
- Interior lights Ac or DC

Heaters

- Jacket Water Heater
- Crankcase Oil Heater

Insulation Blankets

- Features:
(Temperature to 1260°C (2300°F), Non-Combustible, Highly Resistant to Vibration, Oil, Fuel, Grease, and Moisture Resistant Exterior, Personal Protection

Notes



WE ARE THE BEST IN MANUFACTURING THE POWER GENERATION SYSTEMS AND ADDITION CONSTANTLY INOVATION.

www.usga.com.mx
All rights reserved.
Printed in MEXICO

DIMENSIONS

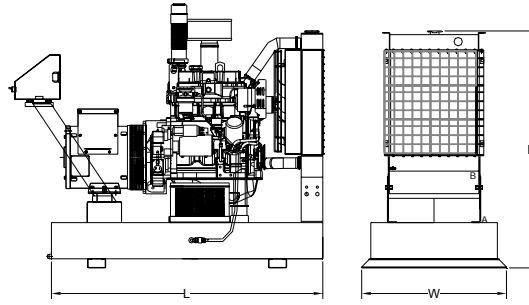

LENGTH	WIDTH	HEIGHT
mm (in)	mm (in)	mm (in)
1500(59.1)	800(31.5)	1310 (51.6)

NOTE: General configuration not to be used for installation. See general dimension drawing for detail.

SERVICES

- Development of the project.
- Development of engineering.
- Equipment's Installation
- Engineering for special applications.
- Synchronies with utility network or more Gensets.
- Attention and technical support

INSTALLATION OPTIONS OF THE GENSET

- On-Site
- Acoustic Enclosure
- ISO Container
- Trailer

