

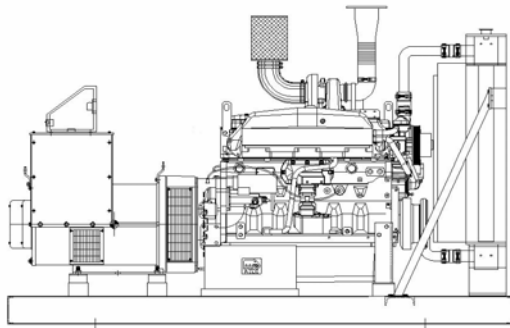

# MAQUINARIA IGSA POWER GENERATION SYSTEMS



**MODEL: GSJD10175M**  
**DIESEL ENGINE: JOHN DEERE**  
**MODEL: 6068HF150, TIER 1**  
**CAPACITY: 175 kW; 1800 RPM**

RATINGS RANGE	
PRIME hp (kW)	STANDBY hp (kW)
186-195 (139-146)	209-218(156-163)

Note: Gross power guaranteed within + or – 5%  
ISO 3046 conditions:  
77°F (25°C) Air inlet temperature  
29.31 in.Hg(99KPa) Barometer  
104 °F (40°C) fuel inlet temperature  
0.853 fuel specific gravity @ 60°F (15.5 °C)

## STANDARD FEATURES

Complete system designed and built at ISO9001 certified facility

- Factory tested to design specifications at full load conditions.
- Fully engineered with a range of options and accessories.

**1 IGSA** Genset's are composed of 6 cylinders and four strokes diesel engine for industrial stationary applications. Those equipments are fully factory tested using a resistive. (1) Hour ramp100% load test.

**2** The controls and accessories are selected to work together to achieve the

maximum operational performance and security.

**3** Exhaust gases silencer, and a section of flexible tube for connection purposes.

**4** Engine **JOHN DEERE, 6068HF150, TIER1.**

**5** Marathon or Stamford Alternator.

**6** Radiator.

**7** Control MEC 310 (panel USC300).

**8** Base of structural steel.

## General Features

- IGSA GENSET of, **175 kW to 480V, 440V, 380V, 220V, 208V, 190VAC**, 3 Phase, 4 Wire, 60 Hertz, is composed by an internal engine four strokes coupling with the alternator, controls and accessories totally assembled and tested in factory.
- The controls and accessories of the Genset are selected to provide the maximum in efficiency and Security.
- The generator set its components are tested factory-built, and production-tested.
- The genset engine is certified by the Environmental Protection Agency (EPA) to conform to Tier 1 nonroad emissions regulations.



**WE ARE THE BEST IN MANUFACTURING THE POWER GENERATION SYSTEMS AND ADDITION CONSTANTLY INOVATION.**

[www.igsa.com.mx](http://www.igsa.com.mx)  
All rights reserved.  
Printed in MEXICO

## ENGINE SPECIFICATION DATA MODEL 6068HF150

### Weight 569 kg (1254Lb)

General Data		
Model	6068HF150	
Number of Cylinders	6	
Bore and Stroke--in.(mm)	4.19 x 5 (106 x 127)	
Displacement--in. <sup>3</sup> (L)	415 (6.8)	
Compression Ratio	17.0 : 1	
Valves per Cylinder--Intake/Exhaust	1 / 1	
Firing Order	1 - 5 - 3 - 6 - 2 - 4	
Combustion System	Direct Injection	
Engine Type	In-line, 4-Cycle	
Aspiration	Turbocharged	
Engine Crankcase Vent System	Open	
Maximum Crankcase Pressure--in.H2O (kPa)	2 (0.5)	
Physical Data		
Length--in.(mm)	44.9 (1141)	
Width--in.(mm)	24.5 (623)	
Height--in.(mm)	39.7 (109)	
Weight, dry--lb (kg) (Includes SAE 4 flywheel housing, RE28119 flywheel, starter and electrics.)	1254 (569)	
Center of Gravity Location		
From Rear Face of Block (X-axis)--in.(mm)	17.2 (438)	
Right of Crankshaft (Y-axis)--in.(mm)	0.05 (1)	
Above Crankshaft (Z-axis)--in.(mm)	6.2 (157)	
Max. Allow. Static Bending Moment at Rear Face of Flywhl Hsg w/ 5-G Load--lb-ft (N*m)	600 (814)	
Thrust Bearing Load Limit (Forward)		
Continuous--lb (N)	500 (2224)	
Intermittent--lb (N)	900 (4003)	
Performance Data	Prime	Standby
Rated Power--hp (kW)	225 (168)	251 (187)
Rated Speed--rpm	1800	1800
Low Idle Speed--rpm	1400	1400
BMEP--psi (kPa)	239 (1650)	266 (1837)
Friction Power		
At Rated Speed--hp (kW)	23 (17)	23 (17)
Altitude Capability--ft (m)	7500 (2300)	5000 (1500)
Ratio--Air : Fuel.	22.6:1	21.7:1
Noise--dB(A) @ 1 m	N/A	N/A
Air System	Prime	Standby
Maximum Allowable Temp Rise--Ambient Air to Engine Inlet--°F (°C)	15 (8)	15 (8)
Maximum Air Intake Restriction		
Dirty Air Cleaner--in.H2O (kPa)	25 (6.25)	25 (6.25)
Clean Air Cleaner--in.H2O (kPa)	12 (3)	12 (3)
Engine Air Flow--ft <sup>3</sup> /min (m <sup>3</sup> /min)	413 (11.7)	441 (12.5)
Intake Manifold Pressure--psi (kPa)	20.3 (140)	22.6 (156)
Rec'd. Intake Pipe Dia--in.(mm)	3 (76.2)	3 (76.2)
Compress Discharge Temp °F (°C)	307 (153)	334 (168)
Max. press. Drop through Charge Air Cooler	52 (13)	52 (13)
Max. Temp. Out of Charge Air Cooler @ 77 °F (25°C) Ambient Air °F (°C)	140 (60)	140 (60)

Electrical System		
Recommended Battery Capacity (CCA)		
12 Volt System--amp		800
24 Volt System--amp		570
Maximum Allowable Starting Circuit Resistane		
12 Volt System--Ohm		0.0012
24 Volt System--Ohm		0.002
Starter Rolling Current -- 12 Volt System		
At 32 F (0 C) -- amp		920
At -22 F (-30 C) -- amp		1300
Starter Rolling Current -- 12 Volt System		
At 32 F (0 C) -- amp		600
At -22 F (-30 C) -- amp		700
Lubrication System	Prime	Standby
Oil Pressure at Rated Speed--psi (kPa)	50 (345)	50 (345)
Oil Pressure at Low Idle--psi (kPa)	15 (105)	15 (105)
In Pan Oil Temperature--°F (°C)	250 (121)	252 (122)
Oil Pan Capacity, High--qt (L)	25 (23.9)	25 (23.9)
Oil Pan Capacity, Low--qt (L)	24 (22.7)	24 (22.7)
Total Engine Oil Capacity With Filters--qt (L)	26 (24.6)	26 (24.6)
Engie Angularity Limits (Continuous) Any Direction--degrees	20	20
Exhaust System	Prime	Standby
Exhaust Flow--ft <sup>3</sup> /min (m <sup>3</sup> /min)	1112(31.5)	1201(34.0)
Exhaust Temperature--°F (°C)	1024 (551)	1056 (569)
Max. Allow. Back Press.--in.H2O (kPa)	30 (7.5)	30 (7.5)
Recm'd Exhaust Pipe Dia--in.(mm)	4 (101.6)	4 (101.6)
Cooling System	Prime	Standby
Engine Heat Reject.--BTU/min (kW)	4040 (71)	4438 (78)
Coolant Flow--gal/min (L/min)	46 (174)	46 (174)
Thermostat Start to Open--°F (°C)	180 (82)	180 (82)
Thermostat Fully Open--°F (°C)	202 (94)	202 (94)
Maximum Water Puma		
Inlet Restriction--in.H2O (kPa)	27 (7)	27 (7)
Engine Coolant Capacity--qt (L)	12 (11.3)	12 (11.3)
Recm'd Pressure Cap--psi (kPa)	10 (69)	10 (169)
Maximum Top Tank Temp--°F (°C)	221 (105)	221 (1105)
Min. Coolant Fill Rate--gal/min (L/min)	3 (11)	3 (11)
Min. Air-to-Boil Temperature--°F (°C)	117 (47)	117 (47)
Fuel System	Prime	Standby
Fuel Injection Pump	Stanadyne	Stanadyne
Governor Regulation	5%	5%
Governor Type	Mechanical	Mechanical
Fuel Consumption--lb/hr (kg/hr)	78.3 (35.6)	86.5 (39.3)
Total Fuel Flow--lb/hr (kg/hr)	212 (96)	212 (96)
Maximum Fuel Transfer Pump Suction ft (m) fuel	3 (0.9)	3 (0.9)
Fuel Filter Micron Size @ 98 % Efficiency	8	8
Fuel Consumption -- lb/hr (kg/hr)	Prime	Standby
25 % Power	21.1 (9.6)	23.1 (10.5)
50 % Power	39.4 (17.9)	44.0 (20.0)
75 % Power	59.8 (27.2)	66.7 (30.3)
100 % Power	78.3 (35.6)	86.5 (39.3)



WE ARE THE BEST IN MANUFACTURING THE POWER GENERATION SYSTEMS AND ADDITION CONSTANTLY INOVATION.

[www.iqsa.com.mx](http://www.iqsa.com.mx)  
All rights reserved.  
Printed in MEXICO

## MARATHON ELECTRIC ALTERNATOR MODEL 431PSL6204 weight 594 kg (1310Lb)

Kilowatt ratings at kW (kVA)	1800 RPM			60 Hertz			12 Leads standard 3 phase		
	3 Phase			0.8 Power Factor			Dripproof or Open Enclosure		
	Class B		Class F				Class H		
Voltage	80° C, 176° F (1)	90° C, 194° F (1)	95° C, 203° F (1)	105° C † British	105° C, 221° F (1)	130° C, 266° F (1)	125° C † British	125° C, 257° F (1)	150° C, 302° F (1)
	Continuous	Lloyds	ABS	Standard	Continuous	Standby	Standard	Continuous	Standby
240/480	143 (179)	155 (194)	160 (200)	170 (213)	170 (213)	181 (226)	170 (213)	180 (225)	190 (238)
230/460	144 (180)	155 (194)	160 (200)	170 (213)	170 (213)	182 (228)	171 (214)	180 (225)	188 (235)
220/440	143 (179)	155 (194)	160 (200)	167 (209)	167 (209)	180 (225)	168 (210)	177 (221)	185 (231)
208/416	142 (178)	152 (190)	156 (195)	165 (206)	165 (206)	176 (220)	165 (206)	175 (219)	182 (228)
190/380	136 (170)	145 (181)	150 (188)	155 (194)	155 (194)	167 (209)	156 (195)	165 (206)	172 (215)

(1) Rise by resistance method, Mil-Std-705, Method 680.1b.

† Rating per BS 5000.

Submittal Data: 240/480 Volts, 219 kVA, 0.8 P.F., 1800 RPM, 60 Hz, 3 Phase					
Mil-Std-705C			Mil-Std-705C		
Method	Description	Value	Method	Description	Value
301.1b	Insulation Resistance	> 1.5 Meg	505.3b	Overspeed	2250 RPM
302.1a	High Potential Test		507.1c	Phase Sequence CCW-ODE	ABC
	Main Stator	2000 Volts	508.1c	Voltage Balance L-L OR L-N	0.2%
	Main Rotor	1500 Volts	601.4a	L-L Harmonic Maximum - Total (Distortion Factor)	5.0%
	Exciter Stator	1500 Volts	601.4a	L-L Harmonic Maximum - Single	3.0%
	Exciter Rotor	1500 Volts	601.1c	Deviation Factor	5.0%
401.1a	Stator Resistance, Line to Line		--	TIF (1960 Weightings)	<50
	High Wye Connection	0.049 Ohms	625.1c	Mechanical Strength (High wye Conection, sustained 3 Phase Short Circuit Current)	<300%
	Rotor Resistance	0.656 Ohms	--	THF (IEC, BS & NEMA Weightins)	<2%
	Exciter Stator	18.5 Ohms	652.1a	Shaft Current	<0.1 ma
	Exciter Rotor	0.116 Ohms	652.2a	Main Stator Capacitance to ground	@0.013 mdf
410.1a	No Load Exciter Field Amps at 480 Volts Line to Line	0.6 A DC	<b>Additional Prototype Mil-Std Methods are Available on Request.</b>		
420.1a	Short Circuit Ratio	0.43	--	Generator Frame	431
421.1a	Xd Synchronous Reactance	2.788 pu	--	Type	Ext. Voltage Regulated, Brushless
422.1a	X2 Negative Sequence Reactance	0.407 pu	--	Insulation	Class H
423.1a	X0 Zero Sequence Reactance	0.024 pu	--	Coupling - Single Bearing	Flexible
425.1a	X'd Transient Reactance	0.178 pu	--	Amortisseur Windings	Full
426.1a	X''d Subtransient Reactance	0.161 pu	--	Cooling Air Volume	1100 CFM
427.1a	T'd Transient Short Circuit Time Constant	0.062 sec.	--	Exciter	Rotating
428.1a	T''d Subtransient Short Circuit Time Constant	0.013 sec.	--	Voltage Regulator	SE350
430.1a	T'do Transient Open Circuit Time Constant	1.46 sec.	--	Voltage Regulation	1%
432.1a	Ta Short Circuit Time Constant of Armature Winding	0.017 sec.	--	Sensing	1 Phase

\* (3) Excitation support system or PMG required to sustain short circuit currents.

\* Voltage refers to wye (star) connection, unless otherwise specified.

\*\* Not supplied as standard equipment.

\*\*\* DVR@2000 voltage regulator supplied with PMG option. DVR@2000 voltage regulation ¼% I or 3 Phase sensing



**WE ARE THE BEST IN MANUFACTURING THE POWER GENERATION  
SYSTEMS AND ADDITION CONSTANTLY INOVATION.**

[www.igs.com.mx](http://www.igs.com.mx)  
All rights reserved.  
Printed in MEXICO

## STAMFORD ELECTRIC ALTERNATOR MODEL UCI274G weight 580 kg (1278.7 Lb)

<b>CONTROL SYSTEM</b>	<b>SEPARATELY EXCITED BY P.M.G.</b>		
<b>A.V.R.</b>	<b>MX321</b>	<b>MX341</b>	
<b>VOLTAGE REGULATION</b>	<b>(+/- 0.5%)</b>	<b>(+/- 1.0%)</b>	<b>WITH 4% ENGINE GOVERNING</b>
<b>SUSTAINED SHORT CIRCUIT</b>	<b>REFERENT TO SHOT CIRCUIT DECREMENT CURRENT</b>		

INSULATION SYSTEM	CLASS H							
PROTECTION	IP23							
RATED POWER FACTOR	0.8							
STATOR WINDING	DOUBLE LAYER CONCENTRIC							
WINDING PITCH	TWO THIRDS							
WINDING LEADS	12							
STATOR WDG. RESISTANCE	0.0199 Ohms PER PHASE AT 22°C SERIES STAR CONNECTED							
ROTOR WDG. RESISTANCE	1.69 Ohms at 22°C							
R.F.I. SUPPRESSION	BS EN 61000-6-2 & BS EN 61000-6-4, VDE 0875G, VDE 0875N. refer to factory for others							
WAVEFORM DISTORTION	NO LOAD < 1.5% NON-DISTORTING BALANCED LINEAR LOAD < 5.0%							
MAXIMUM OVERSPEED	2250 Rev/Min							
BEARING DRIVE END	BALL. 6315 - 2RS. (ISO)							
BEARING NON-DRIVE END	BALL. 6310 - 2RS. (ISO)							
	1 BEARING				2 BEARING			
WEIGHT COMP. GENERATOR	580 kg	1278.7 lb			598 kg	1318.4 lb		
WEIGHT WOUND STATOR	225 kg	496.0 lb			225 kg	496.0 lb		
WEIGHT WOUND ROTOR	210.35Kg	463.7 lb			199.39 kg	439.6 lb		
WR <sup>2</sup> INERTIA	1.7674 kgm <sup>2</sup>	41.9 lbft <sup>2</sup>			1.7169 kgm <sup>2</sup>	40.7 lbft <sup>2</sup>		
SHIPPING WEIGHTS in a crate	613 kg	1351.4 lb			630 kg	1388.9 lb		
PACKING CRATE SIZE	123 x 67 x 103 (cm)	48.4x26.4x40.6(in)			123x 6 x 103 (cm)	48.4x26.4x40.6(in)		
	50 Hz				60 Hz			
TELEPHONE INTERFERENCE	THF<2%				TIF<50			
COOLING AIR	0.514 m <sup>3</sup> /sec 1090 cfm				0.617 m <sup>3</sup> /sec 1308 cfm			
VOLTAGE SERIES STAR	380/220	400/231	415/240	440/254	416/240	440/254	460/266	480/277
VOLTAGE PARALLEL STAR	190/110	200/115	208/120	220/127	208/120	220/127	230/133	240/138
VOLTAGE SERIES DELTA	220/110	230/115	240/120	254/127	240/120	254/127	266/133	277/138
kVA BASE RATING FOR RECTANCE VALUES	180	180	180	N/A	205	218	218	1308
X <sub>d</sub> DIR. AXIS SYNCHRONOUS	2.12	1.92	1.78	N/A	2.43	2.31	2.11	2.06
X' <sub>d</sub> DIR. AXIS TRANSIENT	0.18	0.17	0.16	-	0.21	0.20	0.18	0.18
X'' <sub>d</sub> DIR. AXIS SUBTRANSIENT	0.13	0.12	0.11	-	0.15	0.14	0.13	0.12
X <sub>q</sub> QUAD. AXIS REACTANCE	1.28	1.15	1.07	-	1.47	1.40	1.28	1.24
X'' <sub>q</sub> QUAD. AXIS SUBTRANSIENT	0.17	0.16	0.15	-	0.18	0.17	0.16	0.15
X <sub>L</sub> LEAKAGE REACTANCE	0.08	0.07	0.07	-	0.09	0.08	0.08	0.07
X <sub>2</sub> NEGATIVE SEQUENCE	0.13	0.12	0.11	-	0.16	0.15	0.13	0.13
X <sub>0</sub> ZERO SEQUENCE	0.08	0.07	0.07	-	0.10	0.09	0.08	0.08
REACTANCES ARE SATURATED				VALUES ARE PER UNIT AT RATING AND VOLTAGE INDICATED				
T' <sub>d</sub> TRANSIENT TIME CONST.	0.038 s							
T'' <sub>d</sub> SUB-TRANSTIME CONST.	0.012 s							
T' <sub>do</sub> O.C. FIELD TIME CONST.	1 s							
T <sub>a</sub> ARMATURE TIME CONST.	0.01 s							
SHORT CIRCUIT RATIO	1/X <sub>d</sub>							

RATINGS: All three-phase units are rated at 0.8 power factor. All single-phase units are rated at 1.0 power factor. Standby Ratings: Standby ratings apply to installations served by a reliable utility source. The standby rating is applicable to varying loads for the duration of a power outage. There is no overload capability for this rating. Ratings are in accordance with ISO-3046/1, BS5514, AS2789, and DIN 6271. Prime Power Ratings: Prime power ratings apply to installations where utility power is unavailable or unreliable. At varying load, the number of generator set operating hours is unlimited. A 10% overload capacity is available for a 12 hour period. Ratings are in accordance with ISO-8528/1, overload power in accordance with ISO-3046/1, BS 5514, AS 2789, and DIN 6271. For limited running time and base load ratings, consult the factory. The generator set manufacturer reserves the right to change the design or specifications without notice and without any obligation or liability whatsoever. GENERAL GUIDELINES FOR DERATION: Altitude: Derate 1.3% per 100 m (328 ft.) elevation above 1500 m (5000 ft.). Temperature: Derate 1.0% per 10°C (18°F) temperature above 25°C (77°F).



**WE ARE THE BEST IN MANUFACTURING THE POWER GENERATION  
SYSTEMS AND ADDITION CONSTANTLY INOVATION.**

[www.igsacom.mx](http://www.igsacom.mx)  
All rights reserved.  
Printed in MEXICO

## CONTROLLER FOR GENSET: CONTROL MEC 310 PANEL USC300

The Generator Controller MEC 310 is a microprocessor-based control unit containing all necessary functions for protection and control of a power generator. Besides the control and protection of the diesel engine it contains a full 3-phase AC voltage and current measuring circuit. The unit is equipped with an LCD display presenting all values and alarms.



- USC 300C Unit Mount Control Panel, Black Nema 1 enclosure c/w rubber mounts
- MEC 310 Microprocessor Based Engine Generator Controller
- Graphic Display 128 X 64 pixels (STN) Super Twisted Nematic
- Digital AC Metering:
  - 3-Phase Volts (Phase to Phase and Phase to Neutral),
  - 3-Phase Amps
  - Frequency
  - kW, kVAR, KVA, pF, kWhr
- AC Protective Relaying:
  - 27/59 Under/Over Voltage
  - 32 Reverse Power
  - 51 Time Overcurrent
  - 81 O/U Under/Over Frequency
- Digital gauge display:
  - Oil Pressure (sender required by others)
  - Coolant Temperature (sender required by others)
  - Fuel Level (sender required by others)
  - Hourmeter
  - Tachometer
- 5 digital inputs for alarms / shutdowns
- Dedicated Output Contacts - Engine Crank; Run (30 VDC / 6 Amps)
- Three Programmable Output Contacts (30 VDC / 1 Amps)
- Event Logging (30 events)
- Pushbuttons:
  - Emergency Stop
  - Manual Start and Stop
  - Manual/Auto/Test
  - Lamp Test
  - Horn Silence
- Indicating Lights:
  - Common Alarm
  - Generator Ready (Voltage and Frequency Normal)

## FEATURES

- Electrical Rating:**
- Single or three phase, 600VAC maximum, 50/60HZ, 4 wire
  - 12 or 24Vdc (nominal) supply, negative ground.
  - Dedicated Output Contacts - Engine Crank; Run (30 VDC / 6 Amps)
  - Three Programmable Output Contacts (30 VDC / 1 Amps)
- Enclosure:**
- Black Nema 1 enclosure c/w rubber mounts
- Engine Senders:**
- Oil pressure (1/8" NPT), Temperature (1/4"NPT) (Supplied loose for engine mounting).
- Requirements:**
- Exceeds requirements of CSA 282 and NFPA 110 Level

## OPTIONAL SILENCER ACCORDING TO THE APPLICATION

Silencer with different levels from attenuation

- Critical Grade
- Super Critical Grade
- Hospital Grade

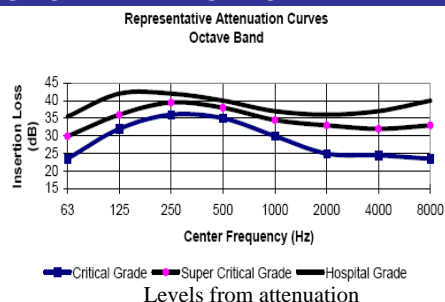

## DOCUMENTATION AND OTHERS

- Manual of operation and maintenance
- Spare parts
- Maintenance
- Consulting

## MISCELLANEOUS EQUIPMENT

- Batteries of 12 VDC with cables for battery connection with the Engine.

### GENSET OPTIONS

#### Control Panel

USC 300C Control Panel is standard on all units see page 4 of spec sheet for standard features.

Another Type \_\_\_\_\_

#### Fuel system

- Fuel Water Separator
- Day tank
- Auxiliary fuel pump
- Sub Base mounted Fuel Tank
  - Single Wall
  - Double Wall
  - UL listed
  - 150 L (39.6 gal)
  - 250 L (66 gal)

#### Diesel Fuel Tank

- 500 L (132 gal)
- 1000 L (264.1 gal)
- 5000 L (1320.8 gal)

#### Exhaust System

- Critical Grade
- Super Critical Grade
- Hospital Grade

#### Engine Electrical system

- Battery
  - Lead-Acid
  - NiCad
- Battery Rack
- Battery Charger Automatic

#### Generator

- Breaker in the alternator

### OPTIONAL ACCESSORIES AVAILABLE FOR THE EQUIPMENT

#### Vibration isolation

- Rigid Spring Mounting
- Resilient Mounting

#### Filters

- Air Filter for Medium Dust Environments
- Air Filter of Heavy Dust Environments

#### Drain

- Oil drain Extension

#### Enclosures

- Sound Attenuated
- Weather Proof
- Stainless steel cover
- Trailer Mounting
- Interior lights Ac or DC

#### Heaters

- Jacket Water Heater
- Crankcase Oil Heater

#### Insulation Blankets

- Features:  
( Temperature to 1260°C (2300°F), Non-Combustible, Highly Resistant to Vibration, Oil, Fuel, Grease, and Moisture Resistant Exterior, Personal Protection

#### Notes

---

---

---

---

---

---

---

---



WE ARE THE BEST IN MANUFACTURING THE POWER GENERATION SYSTEMS AND ADDITION CONSTANTLY INOVATION.

www.iqsa.com.mx  
All rights reserved.  
Printed in MEXICO

## DIMENSIONS

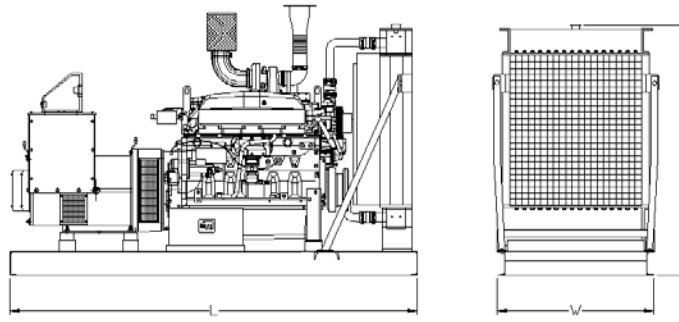

LENGTH	WIDTH	HEIGHT
mm (in)	mm (in)	mm (in)
2700 (106)	1000 (39)	1600 (63)

NOTE: General configuration not to be used for installation. See general dimension drawing for detail.

## SERVICES

- Development of the project.
- Development of engineering.
- Equipment's Installation
- Engineering for special applications.
- Synchronies with utility network or more Gensets.
- Attention and technical support

## INSTALLATION OPTIONS OF THE GENSET

- On-Site
- Acoustic Enclosure
- ISO Container
- Trailer

